



Please complete & return to :  
**TAGMA**  
TOOL AND GAUGE  
MANUFACTURERS  
ASSOCIATION

## AN INVITATION AND A WELCOME

[Page 1](#)

**Sub.: DMI 2008 INTERNATIONAL EXHIBITION.**

**Date : 15TH TO 18TH FEB., 2008.**

**Venue : Bangalore International Exhibition Centre, Tumkur Road, Bangalore.**

Dear sir/ madam,

Tool and Gauge Manufacturers Association [TAGMA] is organizing DIEMOULD INDIA 2008 the 6th Biannual Die & Mould International Exhibition from 15th to 18th Feb., 2008 at Bangalore International Exhibition Centre [BIEC], 10th Mile, Tumkur Road, Bangalore.

The 5th Die & Mould International exhibition held from 3rd to 6th March 2006 at Chennai Trade Centre, Chennai was a huge success **in terms of quality, in terms of spread, in terms of newer innovative technologies and in terms of attracting new exhibitors.** It attracted exhibitors and delegations from all over the world prominently among them being **Australia, Canada, Germany, Italy, Japan, Malaysia, Netherlands, Pakistan, Portugal, Singapore, Slovakia, Spain, Taiwan, Thailand, U.K, U.S.A, etc.** The four day exhibition encouraged the members and those involved in the Tooling industries to see, understand, explore and eventually develop business by getting the latest technology and also going in for tie-ups and joint ventures.

Die & Mould India is the largest International Exhibition held in India providing businesses connected with the tooling industry a prestigious platform to showcase and market their various products.

TAGMA cordially invites you to participate in DMI 2008 and avail of the opportunity to benefit from the growing tool industry.

TAGMA wishes all the exhibitor a grand success in DMI 2008.

**S.C.KALYANPUR**  
**PRESIDENT**



Please complete & return to :  
**TAGMA**  
**TOOL AND GAUGE**  
**MANUFACTURERS**  
**ASSOCIATION**

## FACT SHEET

[Page 2](#)

**ON 6<sup>th</sup> DIEMOULD INDIA  
INTERNATIONAL EXHIBITION AND  
TOOLING IN THE NEXT DECADE VISION 2010 SEMINAR COVERING CURRENT  
AND FUTURE DIE AND MOULD TECHNOLOGIES**

<b>Time Table of site Operations</b>	
Exhibitors	Move in Date
(a) Heavy Exhibits (Machine / Moulds)	13th February 2008, 10 a.m.
(b) Light Exhibits	14th February 2008, 10 a.m.
Completed work on	15th February 2008, 8 a.m.

<b>Time Table</b>	
Possession for Exhibitors:	
Raw Space	12th February 2008, 10 a.m.
Shell Space	14th February 2008, 10 a.m.
Completion of displays	15th February 2008, 8 a.m.
Inauguration of Exhibition	15th February 2008, 10 a.m.
Duration of Exhibition	15th February to 18th February 2008, 10 a.m. to 6 p.m.
Dismantling of Exhibition	On 18th February 2008, 6 p.m. Onwards

<b>Space Rental</b>		
	<b>SHELL STAND</b>	<b>RAW SPACE</b>
Member	Rs. 8000 p.m. <sup>2</sup>	Rs. 7000 p.m. <sup>2</sup>
Non-Member	Rs. 9000 p.m. <sup>2</sup>	Rs. 8000 p.m. <sup>2</sup>
Foreign	USD 230 p.m. <sup>2</sup>	USD 200 p.m. <sup>2</sup>
Minimum area	9 sq. M. <sup>2</sup>	36 sq. M. <sup>2</sup>
2 side open 5% & 3 side open 10% Extra Additional area As required.		
Service Tax	12.24%	

<b>Directory 2008</b>
Free entry for exhibitors as per std questionnaire. Advt details available on request.

<b>Exhibition timings</b>
10 a.m. to 6 p.m

## Utilities

Overall security, watch & ward, conservancy provided free. Charges for electricity and additional utilities, furniture, etc are as per contractual rate.

## Payment

Exhibit Range 50% with booking and balance by 30th December 2007 by local cheque or demand draft only.

## Stand Packages

**Shell Scheme:** Standard Octonorm modular structure with partition, company name, on Fascia carpet: (tables, chairs & spotlights lights depending on area).

**Raw Scheme:** Bare Space only.

## ITPO Approval

144-ITPO(192)/ APP/2006 Date: 22.11.2006

## Exhibit Range

- Dies & Moulds, Press Tools.
- Machine Tools for making Dies & Moulds, C.N.C Milling / machining centre, E.D.M etc.
- Die casting machine / moulding machine.
- CAD / CAM system related to Dies & Moulds.
- Measuring Machines.
- Rapid Prototyping & Modeling.
- Digitizing.
- Accessories for Machine Tools.
- Heat Treatment.
- Cutting Tools.
- Die / Mould polishing machines.
- Mould base and standard parts for Dies & Moulds.
- Die Spotting.
- Hot Runner Systems.
- Texturizing.
- Gauges.
- Tool Steel.

***Cancellation subject to 15% deduction of payment before 30th December 2005 after that 100%. to Cancellation subject to 15% deduction of payment before 30th December 2007 after that 100%.***



## SPACE APPLICATION CONTRACT

Organisation: \_\_\_\_\_

Contact Name : Mr. / Mrs. Ms. \_\_\_\_\_

Designation : \_\_\_\_\_

Address : \_\_\_\_\_

\_\_\_\_\_

City : \_\_\_\_\_ Postal Code : \_\_\_\_\_ Country : \_\_\_\_\_

Tel : \_\_\_\_\_ Fax: \_\_\_\_\_

e-mail : \_\_\_\_\_

**Exhibitor Details** \_\_\_\_\_

\_\_\_\_\_

\_\_\_\_\_

**Stand Allocation and Costs**

Please Tick ( ) ONE of the following options:

OPTION 1 SHELL SCHEME <input type="checkbox"/>		MEMBER	NON MEMBER		
Shell stand:	Rate Per sq. metres	Rs.8000	Rs.9000	USD 230	EURO 185
	Minimum 9 sq. metres	Rs.72000	Rs.81000	USD 2070	EURO 1665
	Additional space <input type="text"/> sqm	<input type="text"/>	<input type="text"/>	<input type="text"/>	<input type="text"/>
	Add Service Tax 12.24%	<input type="text"/>	<input type="text"/>	<input type="text"/>	<input type="text"/>
		<b>INDIAN</b>		<b>FOREIGN</b>	
<b>OPTION 2 RAW SPACE</b>		<b>MEMBER</b>	<b>NON MEMBER</b>		

Raw Space :	Rate Per sq. metres	<b>Rs.7000</b>	<b>Rs.8000</b>	<b>USD 200</b>	<b>EURO 160</b>
	Minimum 36 sq. metres	Rs.252000	Rs.288000	USD 7200	EURO 5760
	Additional space <input type="text"/> sq.	<input type="text"/>	<input type="text"/>	<input type="text"/>	<input type="text"/>
	Add Service Tax 12.24%	<input type="text"/>	<input type="text"/>	<input type="text"/>	<input type="text"/>

**Details of Payment :**

- 1) Demand Draft In favor of "TOOL AND GAUGE MANUFACTURERS ASSOCIATION" PAYABALE AT MUMBAI OR  
2) US DOLLAR REMITTANCE: Wachovia Bank, N.A. NY, SWIFT ADD: PNBPUS 3 NN YC CHIPS ABA 0509 FED ROUTING NO. 026005092 For Credit of A/C NO. 2000191061710 OF INDIAN OVERSEAS BANK, A/c Bank A/c CD 1881 INDIAN OVERSEAS BANK MUMBAI, Nand Jyot Indl. Estate Branch (0386)  
EURO Remittance: American Express Bank, Frankfurt, Swift AEIBDEFX A/c No. 18160608 of Indian Overseas Bank, Chennai, For further Credit to: Indian Overseas Bank, Mumbai Nand Jyot Indl. Estate, A/c No. 1881 Tool and Gauge Manufacturers Association .

**PLEASE NOTE THAT CONFIRMATION OF YOUR BOOKING IS SUBJECT TO RECEIPT OF 50% ADVANCE PAYMENT WITH APPLICATION**

Authorised Signature : \_\_\_\_\_ Name : \_\_\_\_\_

Designation : \_\_\_\_\_ Booking Date : \_\_\_\_\_



## FREE DIRECTORY ENTRY

Please complete in block capital letters correctly typed. **We will fill in the stand number.**

STAND NO.

Company Name \_\_\_\_\_

Address: \_\_\_\_\_

\_\_\_\_\_

\_\_\_\_\_

Phone No : \_\_\_\_\_ Fax No : \_\_\_\_\_

E-mail: \_\_\_\_\_

Exhibits: \_\_\_\_\_

\_\_\_\_\_

\_\_\_\_\_

\_\_\_\_\_

\_\_\_\_\_

Production Specialities : \_\_\_\_\_

\_\_\_\_\_

\_\_\_\_\_

\_\_\_\_\_

\_\_\_\_\_

Please indicate under which letter of the alphabet your company is to be listed. →

Signature

Name

Designation

[TOP](#)



Please complete & return to :  
**TAGMA**  
TOOL AND GAUGE  
MANUFACTURERS  
ASSOCIATION

## TERMS AND CONDITIONS

[Page 5](#)

**GUIDELINES : DIEMOULD INDIA-2008**  
**BANGALORE INTERNATIONAL EXHIBITION CENTRE, BANGALORE**  
**VISITOR TIMING : 10 A.M. TO 6 P.M.**

- 1) POSSESSION OF SPACE FOR BUILD UP AND PLACEMENT OF MACHINERY AND OTHER EXHIBITS :** Raw space builtup & machinery : 13th Feb. 10:00 am. For Shell Stand without machinery : 14th Feb. 10:00 am.
- 2) INAUGURATION :** 10 a.m. on 15th Feb. 2008.
- 3) DISMANTLING :** On 18th Feb. 2008 from 6 p.m. onwards and to be completed by 8 a.m. on 19th Feb. 2008. Vacant possession of the stand area to be handed over by 10 a.m. on 19th Feb. 2008.
- 4) ACCOUNTS :** To be settled before close down on 17th Feb. 2008, 4 p.m.
- 5) EXHIBITS :** See Fact Sheet.
- 6) DEMONSTRATION OF MACHINERY & EQUIPMENT:** All prescribed safety measures will be observed, particularly those relating to fire, heat and all other hazards to life, limb and property. Operating areas should be fenced off as a precautionary measure.
- 7) REGULATIONS :** a) Exhibitor activity will be confined to the area allotted. There should be no abutting into common areas, passages or adjoining stands. b) Sub-letting of space is prohibited. c) Comprehensive insurance is in the interest of the exhibitor. d) TAGMA stands indemnified automatically.
- 8) SITE HANDLING AND SERVICES TARIFF :** Available on request. Also will be sent as soon as booking is received.
- 9) FRIEGHT FORWARDING & CLEARING AGENCY :** Available on request.
- 10) ACCOMODATION :** Hotels offering concessional tariffs will be sent to all participants.
- 11) COMMON SERVICES :** Include general illumination and hall lighting, carpeting of aisles and passages, exhibitor passes, free entry in the directory and a copy of the directory to each exhibitor.
- 12) ADDITIONAL FURNITURE & FITTING :** Details available on request.
- 13) DIRECTORY :** Directory entries will be published as per details provided by the exhibitor in the questionnaire.

**14) ADVERTISERS :** Advertisers will be given a voucher copy of the Directory with the Bill. Advertisements charges are to be paid in advance.

**15) GENERAL INFORMATION :** 1) Bangalore International Exhibition Centre authorities from whom TAGMA has rented the exhibition premises have instructed us to follow their Manual which inter alia, states that - a) Digging, painting of walls etc. will not be allowed and damages, if any, have to be compensated by the exhibitor. b) Adequate fire precautions should be taken (fire extinguishers are available from the contractors on hire) 2. TAGMA decision on all matters is final and binding. 3. All costs and consequences on any account are the liability of the exhibitors including Customs, Central Excise, Municipal Corporation and Bangalore International Exhibition Centre Site.

**16) DUTY EXEMPTION :** (1) INDIA TRADE PROMOTING ORGANISATION (ITPO) has approved DIEMOULD INDIA 2008 and issued ATA Carnet facility under notification ITPO Approved No.144-ITPO(192)/APP/2006 Customs at Mumbai, Kolkata, Bangalore, Chennai, & New Delhi have been informed accordingly. (2) The Dy. Assessor & Collector, Bangalore Municipal Corporation has also been intimated with a request for exemption of Octroi . (3) The Assistant Collector Central Excise has the authority under "General exemption No. 15" to extend bond facilities for movement of exhibits to and fro within specified time limits. (4) Octroi at place of origin : Exhibitors are advised to contact the Municipal authorities of their respective areas for completing the formalities there, to enable outward and inward movement of exhibits without incurring octroi payment at their respective Octroi posts. Separate manual will be sent to exhibitors in due course.

**17) GATE PASS :** TAGMA will issue gate pass for removal of exhibits as per original lists of exhibits brought in and certified at site. (Exhibitor settle all their bill before taking Gate Pass)

**18) EXHIBITOR BADGES :** These will be available at the exhibition registration desk.

**19) INDEMNITY FORM :** This will also be made available at the registration desk which may be duly completed signed and returned by the exhibitor.

[TOP](#)



# PROPOSED LAYOUT FOR DIEMOULD INDIA - 2008

## Hall I: Lower Level

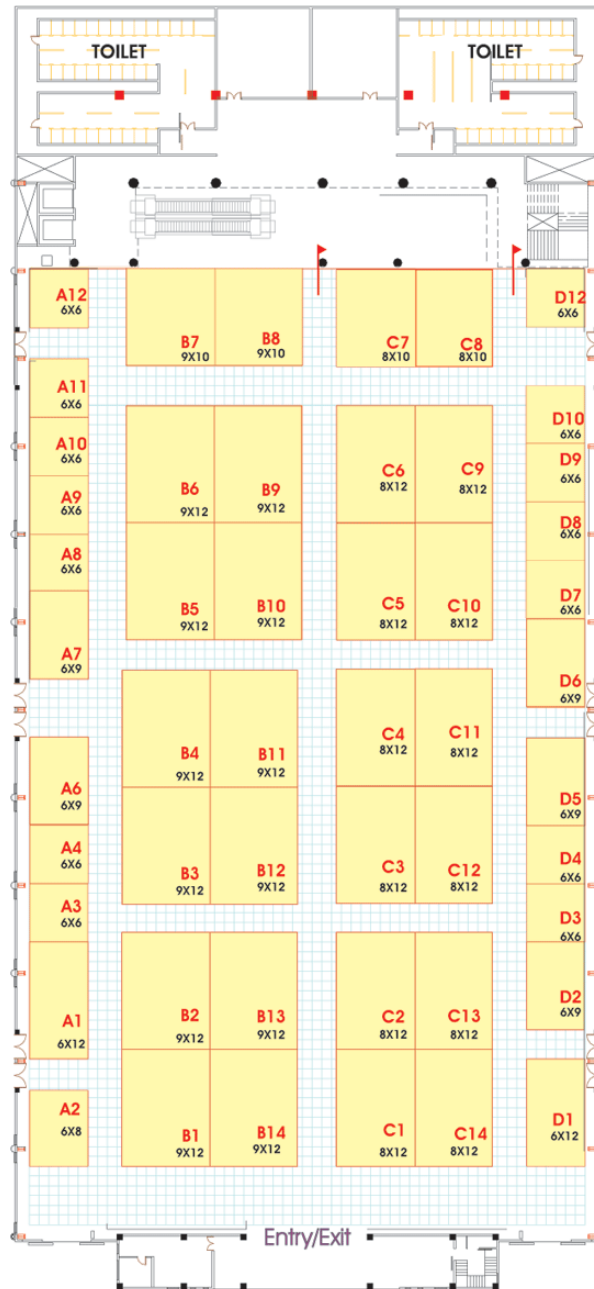

# Hall I: Upper Level

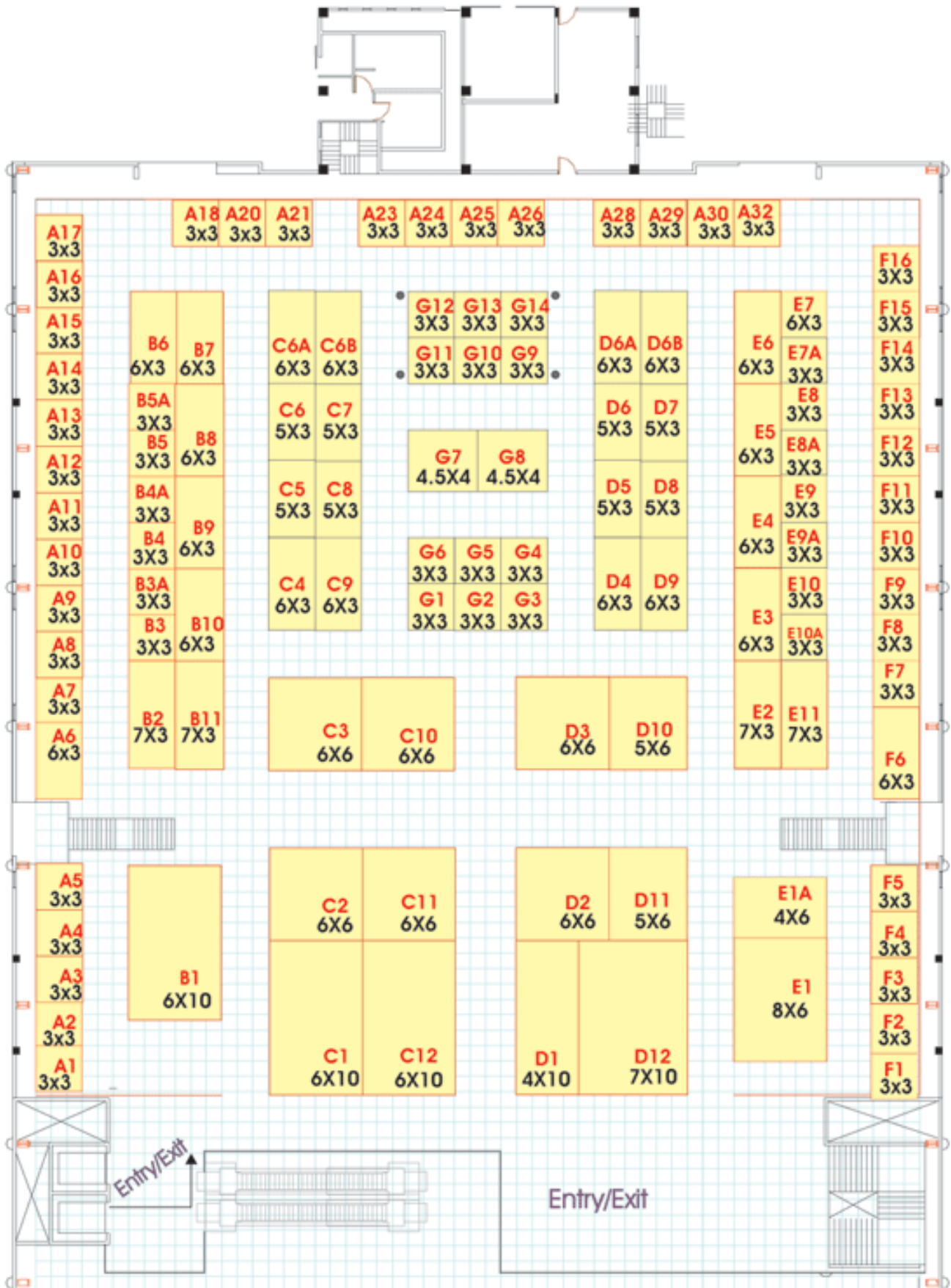

# Hall II: Lower Level

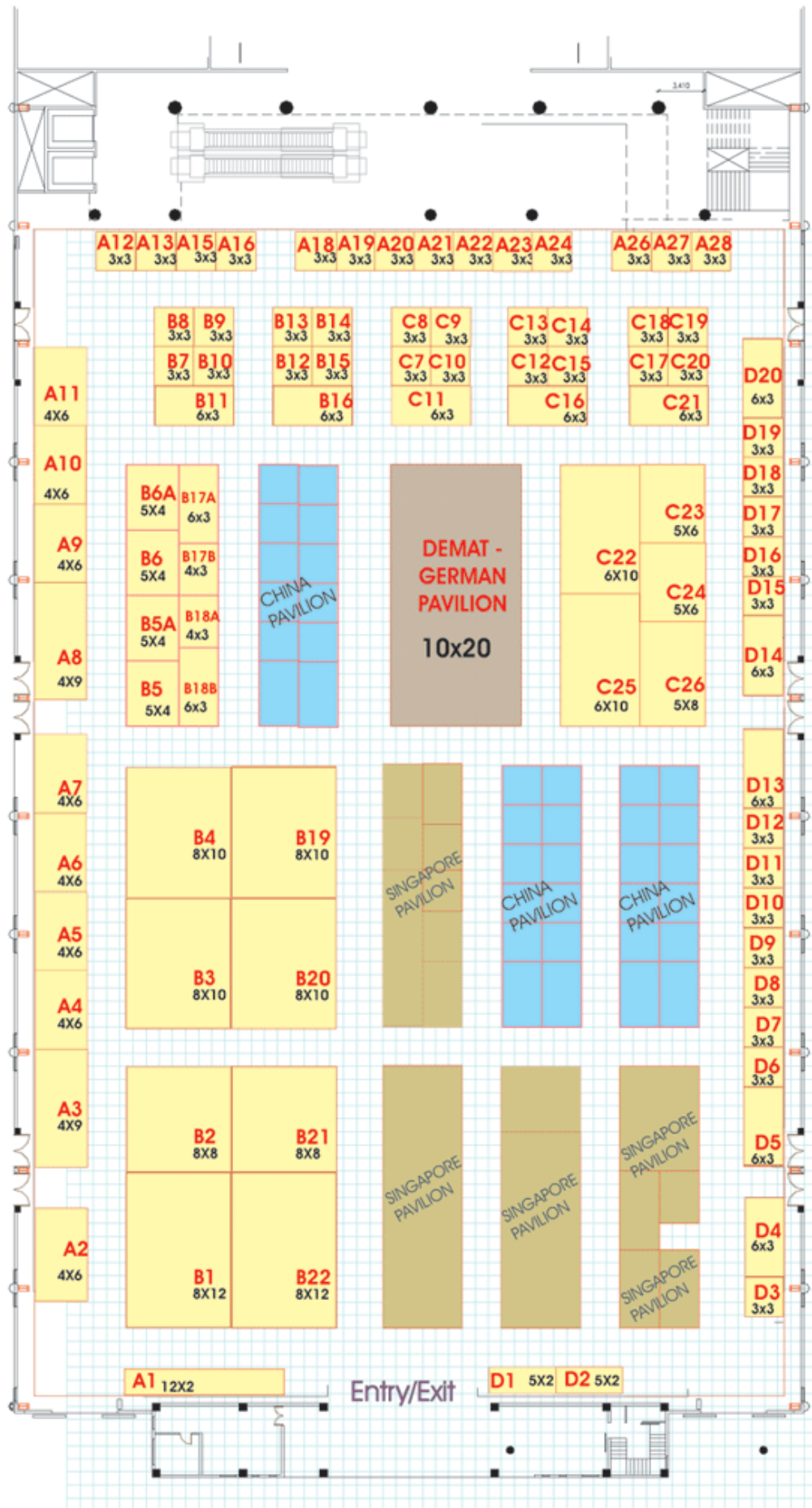



Please complete & return to :  
**TAGMA**  
TOOL AND GAUGE  
MANUFACTURERS  
ASSOCIATION

## ADVERTISEMENT IN DIRECTORY

[Page 7](#)

Please complete in block capital letters correctly typed. This form along with material & payment should be sent on or before 15th November, 2007.

Company Name \_\_\_\_\_

Address \_\_\_\_\_  
\_\_\_\_\_

Phone \_\_\_\_\_

Fax \_\_\_\_\_

Date \_\_\_\_\_

E-Mail \_\_\_\_\_

Name of Signatory \_\_\_\_\_

Please reserve the following advertising space in the DIEMOULD INDIA - 2008 Directory:

ADVERTISING RATES	Indian Advertisements Four Colour	Foreign Advertisements Four Colour
	Rs.	USD
Full A5 Page	10000	300
Front Inside	14000	400
Back Inside	14000	400
Back Cover	20000	NA
Section Separator / Divider	12000	370
Double Spread	19000	450

## TECHNICAL DATA & DETAILS :

- a) Size:- Print area 12 cms. X 19.5 cms  
Bleed Size 14 cms. X 22 cms
- b) Booking first on first come reserved basis
- c) Material: Four color positives are only accepted  
if artwork is sent, actual processing cost will be charged extra
- d) Payment: DD/ cheque payable to **TOOL AND GAUGE MANUFACTURERS  
ASSOCIATION, MUMBAI**
- e) Color printing Sinar Mass Art paper

[TOP](#)



Please complete & return to :  
**TAGMA**  
**TOOL AND GAUGE**  
**MANUFACTURERS**  
**ASSOCIATION**

# STANDARD SHELL SCHEME BOOTH ( 3M X 3M )

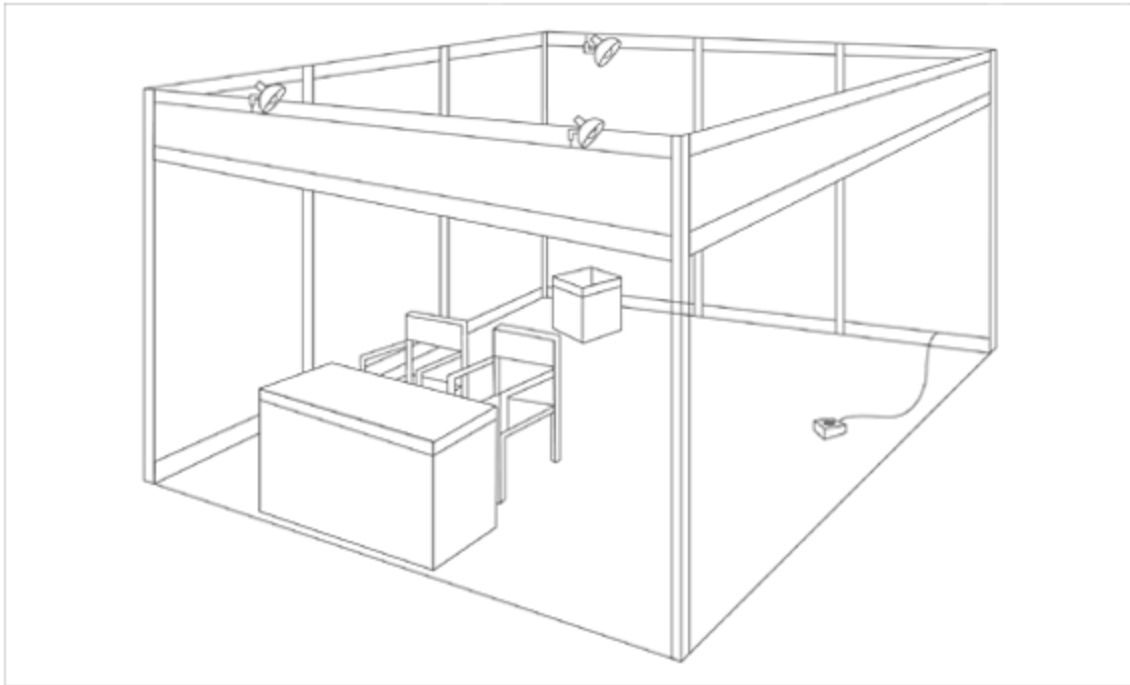

## STANDARD EQUIPMENT SUPPLIED WITH BUILT - UP BOOTHS

Area	Chair	Table	Round Table	Spot Light	Socket	W.P.B.
9	2	1	-	3	1	1
12	2	1	-	6	1	1
18	3	2	-	9	1	1
24	6	2	-	12	2	2
36	8	3	1	15	2	2
42	10	3	1	18	4	3

NOTES : No Nailing or painting is allowed on aluminium frames and panels

[TOP](#)



Please complete & return to :  
**TAGMA**  
**TOOL AND GAUGE**  
**MANUFACTURERS**  
**ASSOCIATION**

## A TYPICAL (3M X 3M ) BOOTH

**FRONT PERSPECTIVE VIEW**

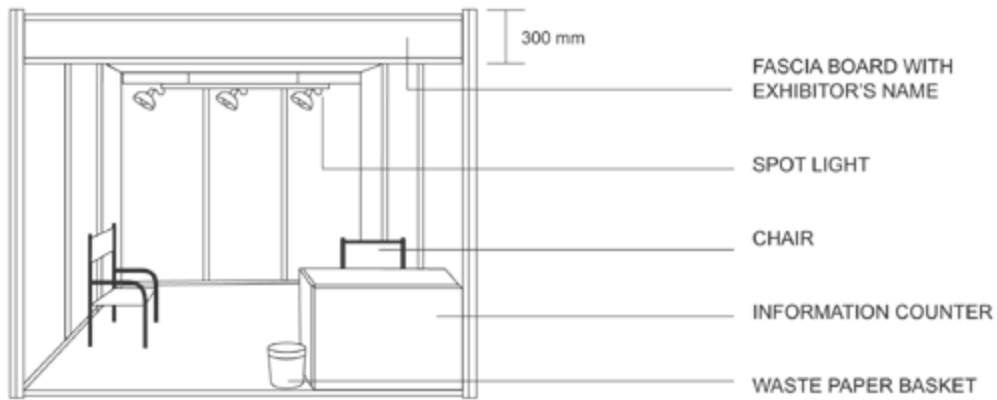

**SIDE SECTIONAL ELEVATION**

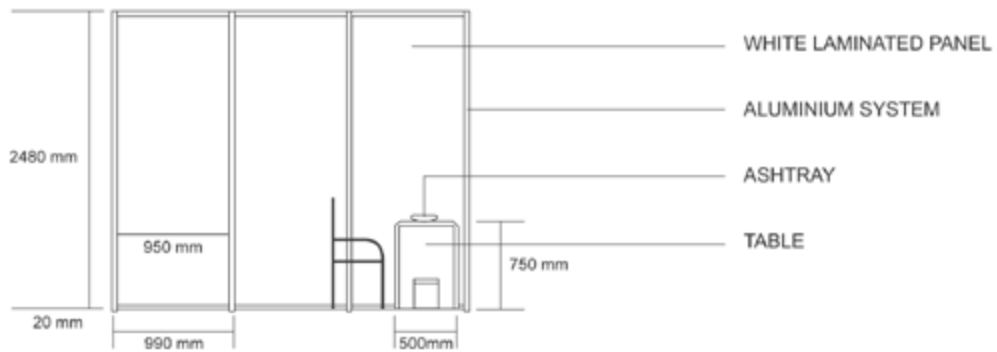

**FLOOR PLAN**

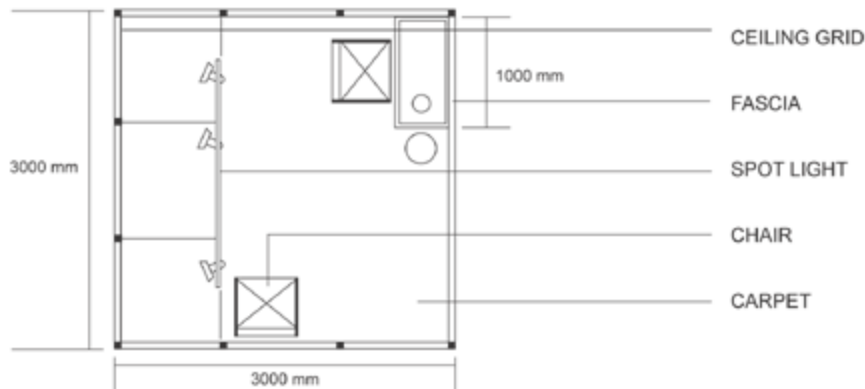

[TOP](#)



Please complete & return to :  
**TAGMA**  
**TOOL AND GAUGE**  
**MANUFACTURERS**  
**ASSOCIATION**

**CITY & VENUE (BIEC) INFORMATION**

## INTRODUCTION TO BANGALORE

Bangalore is the capital city of the southern Indian state of Karnataka originated in early 15th Century. It is the seventh largest city in India. It is also known as the Garden City because of its many beautiful gardens and parks. The nandi hills in Bangalore is not to be missed. Though the origin of Bangalore is ancient, the present-day city was founded in the 16th century and has since continued to be an important administrative center.

Because of the high concentration of IT industry, it is also called the Silicon Valley of India. There are a number of good hotels and service apartments in Bangalore that make your stay in the Garden city comfortable.

## LOCATION OF BANGALORE

Bangalore city is located in the southern part of the state of Karnataka, in the southern region of India.



It is 3,113 feet (949 m) above sea level, on top of a ridge in the Karnataka plateau. Bangalore is 998 km from Mumbai (Bombay) and 562 km from Hyderabad. The climate of Bangalore is moderate and pleasant throughout the year. Summers are mild (April - June) and winters are cool (October-February). The city experiences southwestern monsoon rains in June-August.

## HISTORY OF BANGALORE

Legend has it that the city is named after an old woman, who lived in this area and offered a humble meal of boiled beans to a lost Hoysala ruler. The origin of the present-day city of Bangalore can be traced to the early 16th century, when Kempegowda, a local chief, built a small mud fort here. Bangalore gained prominence in the 18th century, when it became an important fort city, under Hyder Ali and Tipu Sultan of Mysore. This area witnessed the struggle between Tipu Sultan and the British. The British defeated Tipu Sultan and took over Bangalore city. In 1831, the British made it the regional administrative city and established a big cantonment here.

## PLACES OF TOURIST INTEREST IN CITY

- Vidhan Soudha
- Cubbon Park
- Lalbagh
- ISKON
- Bull Temple

- Museums
- Govt. Museums and Visvesvaraya Technological & Industrial Museum
- The 18th-century Tipu Sultan's Fort and Palace
- Bannerghatta National Park
- Mysore-the historic city-139 kms. Old temples and shrines like Devarayandurga, 70 km etc.



## India Trade Promotion Organisation

भारत सरकार का उद्यम  
A Government of India Enterprise

Reference: 144-ITPO (192)/APP/2006

Date: 22-11-2006

Phone: 23371824

**Tool and Gauge Manufacturers Association**  
C/o NTTF Industries Ltd.,  
23/24 Peenya Industries Area, 11Phase,  
Bangalore-560 058.

**Sub: Approval for holding DIEMOULD INDIA 2008-International  
Exhibition during February 15-18,2008 at Bangalore  
International Exhibition centre, Bangalore.**

**Ref: Your Application dated 26-10-2006 & letter dated 7-11-2006.**

Dear Sirs,

India Trade Promotion Organization (ITPO), in exercise of powers conferred on it vide Customs Notification NO.3 dated 9-1-1989 as amended by NotificationNo..66 dated 16-3-1995, is pleased to approve the holding of the above event subject to the following:

(a) Products covered: Dies & Moulds, Press Tools for making Dies & Moulds,CNC Milling/Machining Center, E.D.M. Etc. Die Casting Machine/Moulding Machine, CAD/CAM system related to Dies & Moulds, Measuring Machine, Rapid Prototyping & Modeling, Digitising, Accessories for Machine Tools, Heat treatment, Cutting Tools, Die/Mould polishing machines, Mould base and standard parts for Dies & Moulds, Die Spotting and Hotrunner systems.

(b) Overseas Participation form: Australia, Canada, Germany, Hong Kong, Israel, Italy, Japan, Korea, Netherlands, Singapore, Slovenia, Sri Lanka, Sweden, Switzerland, Taiwan,Thailand, U. K.. U.S.A., Belgium, France, Spain, China, Norway, Finland, Malaysia, Philippines, Indonesia, Nigeria, Brazil, Egypt, South Africa, Turkey, Poland, Holland, Denmark, Portugal, Greece, Romania, Bulgaria, Kenya, Ireland, U.S.S.R., Czech Republic, Dubai, U.A.E., Hungary, Slovakia & Luxemburg.

NOTE: In case of participation form Taiwan, you are advised to obtain NOC from Co-ordination Division, Ministry of External Affairs, Govt. Of India, New Delhi, and Ministry of Home Affairs, Govt. Of India, New Delhi.

(c) The approval is issued to your organization and not to any individual person or participant in your exhibition. The facility of duty free temporary import will be available only to foreign exhibitors/participants, who have confirmed their participatio in the above exhibition by remitting participation fee in foreign exchange, Temporary import will be allowed under ATA Carnet System and/or against Undertakings, Bond or Bank Guarantee as required by the Customs authorities in India. In this connection, Ministry of Finance (Department of Revenue) Notifications No.157/90-Cus, 14/90-(NT)-Cus, No.158/90-Cus all dated

28-3-90, as amended from time to time Central Board of Excise and Customs circular No.55-CBEC dated 3-8-1998, etc. Refer.

(d) The exhibition will be open to general public or to a particular section of the general public for which it has relevance; and will be in public interest.

(e) The goods will be re-exported within a period of six months from the date import or any other period, as may be stipulated by the Customs Authorities in India.

(f) Parties/exhibitors whose intention is to sell or dispose of exhibits in India should not avail the facility of duty-free import of exhibits facility extended through this letter.

(g) Participation charges from all foreign participants should be collected in foreign currency. Temporary importation may be facilitated only to those exhibitors who pay participation charges in foreign exchange.

(h) The approval is in no way indicative of sponsorship or support of the event by ITPO and any projection of such indication by the organizers by using the name or logo of ITPO would render withdrawal / cancellation of this letter.

(i) ITPO reserves the right to withdraw/cancel the approval at time without assigning any reason.

(j) A copy of the report of the event with one copy of fair catalogue/exhibitors list should be submitted to ITPO within one month of the conclusion of the event.

Please acknowledge receipt of this letter.

Yours faithfully,

(Rashmi Kalia)  
Dy. General Manager (Mktg.)

[TOP](#)



Please complete & return to :  
**TAGMA**  
TOOL AND GAUGE  
MANUFACTURERS  
ASSOCIATION

**EXHIBITORS LIST**

[Page 11](#)

3D CONCEPT TOOLING	BANGALORE
A.R.MOULDS DIES	COIMBATORE
ABHIJEET DIES TOOLS (P) LTD	MUMBAI
ACE MANUFACTURING SYSTEMS LTD	BANGALORE
ADEPT POLYMERS P LTD	BANGALORE
AGIE CHARMILLES (SOUTH EAST ASIA) PTE LTD	BANGALORE
Alfred Jäger GmbH – Jäger High Performance Spindles	Germany
ALIGNMENT TOOL (S) PTE LTD	SINGAPORE
ALPHACRAFT (P) LTD	COIMBATORE
ALTAIR ENGINEERING	BANGALORE
ANAND MOULD STEELS P LTD	NAVI MUMBAI
APSOM INFOTEX LIMITED	NEW DELHI
ASSAB SRIPAD STEELS LTD	CHENNAI
ASSOCIATED ENGINEERING SERVICES	CHENNAI
August Rugeberg GmbH Co. Kg PFERD - Werkzeuge	Germany
AUTO CLUSTER DEVELOPMENT AND RESEARCH INSTITUTE LIMITED	PUNE
AVI OILLESS DIE COMPONENTS INDIA P LTD	PUNE
BEST ENGINEERING AIDS CONSULTANCIES	BANGALORE
BHARAT FRITZ WERNER LTD	BANGALORE
BHAT METALS RESEARCH P LTD	BANGALORE
BLUM-NOVOTEST GmbH	GERMANY
BODYCOTE METALLURGICAL SERVICE INDIA P LTD	PUNE
Botzian Kirch GmbH	Germany
BRAKES INDIA LTD	CHENNAI
CAPARO ENGG INDIA PVT LTD	Kanchipuram Dist,
CARL ZEISS INDIA P LTD	BANGALORE
CHOICE PRECITECH INDIA P LTD	HYDERABAD
CIMTRIX SYSTEMS P LTD	BANGALORE
CIXI GUANHAIWEI LONGHAI MOULD FACTORY	ZHEJIANG, CHINA
CLASSIC MOULDS DIES	CHENNAI
COBRA CARBIDE P LTD	BANGALORE
CONCORD UNITED PRODUCTS P LTD	BANGALORE
CRAFTSMAN AUTOMATION PVT LTD	COIMBATORE
CRANES SOFTWARE INTERNATIONAL LTD	BANGALORE
DALIAN DONGFEI SPECIAL STEEL PRODUCTS CO LTD	DALIAN
DALIAN DONGMING PRECISION MOLD CO., LTD	DALIAN
DELCAM SOFTWARE INDIA P LTD	PUNE
DESIGNCELL CAD/CAM SOLUTIONS	MUMBAI
DEVU TOOLS P LTD	MUMBAI
DIETECH INDIA P LTD	CHENNAI
DIJET INDUSTRIAL CO., LTD	JAPAN
D-M-E COMPANY INDIA P LTD	BANGALORE
DMG DECKEL MAHO GLIDEMEISTER (INDIA) P LTD	BANGALORE
DORRIES SCHARMANN TECHNOLOGIE GMBH 'DROOP+REIN'	GERMANY

DRASS MECHATRONICS MACHINERY PVT LTD	BANGALORE
DUTTA DASGUPTA	KOLKATA
DYNASCAN INSPECTION SYSTEMS COMPANY	BANGALORE
EDELSTAHL AGENCIES P LTD	MUMBAI
ELECTRONICA MACHINE TOOLS LTD	PUNE
ELECTROPLASTS P LTD	BANGALORE
EOS GmbH India branch office,	CHENNAI
EQIC DIES MOULDS ENGINEERS P LTD	HYDERABAD
ESCHMANN TEXTURES INDIA P LTD	VASAI (E)
ESPIRIT by DP TECHNOLOGY	USA
EUC TECH	CHENNAI
EUNION SINGA PORE PTE LTD	SINGAPORE
F.ZIMMERMANN GmbH	DENKENDORF
FALCON TOOLINGS	COIMBATORE
FANUC INDIA PRIVATE LTD	BANGALORE
FARMAX MACHINES PVT LTD	BANGALORE
FIBRO GmbH, WERK II	GERMANY
FIDIA S.P.A	ITALY
FLEXSPEED MACHINING SOLUTIONS P LTD	BANGALORE
Fooke GmbH	Germany
FORBES GOKAK LTD	MUMBAI
FRANCIS EXIM PVT.LTD	MUMBAI
FUJIAN FIVE BROTHERS MOULD SCIENCE TECHNOLOGY CO., LTD	FUJIAN, CHINA
G.W.PRECISION TOOLS INDIA P LTD	BANGALORE
GANESH MACHINE TOOLS	CHENNAI
GEOMETRIC TECHNOLOGIES INC	USA
GLOBAL SPECIAL SPRINGS P LTD	Gujarat
GODREJ BOYCE MFG. CO. LTD	MUMBAI
GOEL STEEL COMPANY	CHENNAI
GTM TECH GLOBAL TOP TECHNOLOGY TRADING MOLD MANUFACTURE	KOREA
GUHRING INDIA PVT LTD	BANGALORE
GUINDY MACHINE TOOLS LTD	CHENNAI
GWANGJU ASSOCIATION FOR DIE MOLD INDUSTRY DEVELOPMENT	GWANGJU, KOREA
HAAS AUTOMATION INC	CALIFORNIA
HASCO INDIA P LTD	BANGALORE
HAUZER TECHNO COATING	THE NETHERLANDS
HIGHTEMP FURNACES LTD	BANGALORE
HITACHI METALS LTD	SINGAPORE
HOTSET INDIA P LTD	BANGALORE
HUBEI EFENG DIE MOLD CO. LTD	HUBEI, CHINA
HUNAN BOYUN-DONGGANG POWDER METALLURGY CO., LTD	HUNAN
HURCO (S.E.ASIA) PTE LTD	SINGAPORE
HWACHEON ASIA PACIFIC PTE LTD	SINGAPORE
HYDERABAD DIES MOULDS	HYDERABAD

HYS MOULD	GUANGDONG, CHINA
IMDC PSG HOT RUNNER SYSTEMS	HARYANA
INCOE SINGAPORE PTE LTD	SINGAPORE
INDUSTRIAL TOOLING SYSTEM	CHENNAI
IRIS MANUFACTURING LTD	TAMILNADU
JBJ MACHINE TECHNOLOGIES PVT. LTD	NOIDA
JIANGYIN JINGHUA MOULD INDUSTRY CO., LTD	CHINA
JIAXING NYC INDUSTRIAL CO., LTD	ZHEJIANG, CHINA
JYOTI CNC AUTOMATION P LTD	RAJKOT
JYOTI TOOLINGS PRESS COMPONENTS PVT LTD	PUNE
K VALUE CONSULTANTS	PUNE
KA SHIN TECHNOLOGIES (S) PTE LTD	SINGAPORE
KALYANI MOULD BASE P LTD	THANE
KARTHIGEYA MOULDS DIES P LTD	CHENNAI
KARTHIGEYA PLASTICS TECHNOLOGIES P LTD	CHENNAI
KEMET FAR EAST PTE LTD	SINGAPORE
KESHRUP SYSTEMS P LTD	VASAI (E)
KIMANN METAL SPECIALISTS PVT LTD	BANGALORE
KINETIC ENGINEERING LTD (KINETIC TECHNOLOGIES)	PUNE
KOMTECH PLASTIC TECHNOLOGIES (I) PVT LTD	BANGALORE
KTM TECHNO MOULDS PVT LTD	
LAKSHMI DESIGNERS	BANGALORE
Lang GmbH + Co. KG	Germany
LARSEN TOUBRO LIMITED	MUMBAI
LAXMI ELECTRONICS	BANGALORE
LAXMI VACUUM HEAT TREATERS	BANGALORE
Leonhardt Graveurbetrieb	Germany
LMT FETTE (INDIA) PVT LTD	CHENNAI
LOKESH MACHINE TOOLS	HYDERABAD
LONG TECH ENGINEERING PTE LTD	SINGAPORE
LUNG KEE GROUP	HONGKONG
M D CORPORATION	NEW DELHI
MADHU MARKETING SERVICES	VADODARA
MADHUKAR ENGINEERING COMPONENTS	DHARWAD
MAGOD LASER MACHINING PVT LTD	BANGALORE
MAHARSHI TOOLS PVT LTD	THANE
MAHINDRA MAHINDRA LTD.,	NASIK
MAKINO INDIA PVT LTD	BANGALORE
MARPOSS INDIA PVT LTD	BANGALORE
MASTERCRAFT ENGINEERS P LTD	BANGALORE
MDL	FRANCE
MEDHA AUTOMATION TOOLS INDIA	BANGALORE
MELCO ENGRAVING INDIA P LTD	BANGALORE
METALS - INDIA	HARYANA

MICRO TOOLING SYSTEMS CHENNAI P LTD	CHENNAI
MICROGENESIS CADSOFT PVT LTD.	BANGALORE
MILLUTENSIL	MILANO, ITALY
MISUMI (THAILAND) CO., LTD	THAILAND
MITSUBISHI ELECTRIC ASIA PTE LTD	SINGAPORE
MITUTOYO SOUTH ASIA P LTD	NEW DELHI
MMC HARDMETAL INDIA P LTD	BANGALORE
MODULAR MOLD SOLUTIONS P LTD	CHENNAI
MOLD MASTERS TECHNOLOGIES PVT LTD	COIMBATORE
MOLDFLOW SINGAPORE PTE LTD	PUNE
MULTIPLE AGENCIES (BOMBAY)	BANGALORE
NEBASHI CNC AUTOMATION P LTD	HYDERABAD
NECUMER - PRODUCT GMBH	GERMANY
NEETA ENGINEERS PRECISION TOOLS PVT LTD	PUNE
NEXTGEN CNC HYTEK PVT.LTD	PUNE
NGK MACHINE TOOLS (S) PTE LTD	SINGAPORE
NICKUNJ EXIMP ENTERPRISES P LTD	MUMBAI
NIHON TRADING COMPANY	BANGALORE
NIKON SINGAPORE PTE LTD	SINGAPORE
NINGBO SANHAN TOOLS MANUFACTURE CO., LTD	CHINA
NINGBO YUEFEI MOULD CO., LTD	ZHEJIANG, CHINA
NINGHAI FIRST RATE INJECTION MOULD FACTORY	ZHEJIANG, CHINA
NTS TOOLING INDIA PVT LTD	NOIDA
NTTF INDUSTRIES LTD	BANGALORE
NUCON TECHNOLOGIES PVT LTD	CHENNAI
NUTECH CNC P LTD	CHENNAI
O.R. Lasertechnologie GmbH	Germany
OM ENTERPRISES	MUMBAI
OMNI MATRIX PVT. LTD	BANGALORE
ONWARD TECHNOLOGIES LTD	PUNE
OPENMIND TECHNOLOGIES	BANGALORE
OPTICAL GAGING (S) PTE LTD	SINGAPORE
ORION IMPEX PVT. LIMITED	DELHI
P.DALAL CO. P LTD	MUMBAI
PCK BUDERUS (INDIA) SPECIAL STEELS P LTD	CHENNAI
PI-TECH INTERNATIONAL	NEW DELHI
PI-TECH SERVICES	NEW DELHI
PMT MACHINE LIMITED	PUNE
POLYSMART TECHNOLOGIES PVT LTD	MUMBAI
PRECIOUS PRODUCTS (INDIA) P LTD	PUNE
PRECISION PUNCHES DIES	MUMBAI
PRECISION TOOLS IMPLEMENT CO	BANGALORE
PRE-MOULD ENGINEERS	HYDERABAD
PRIME INDUSTRIES	NASIK

PRINCE DESIGN-N-TOOLING TECHNOLOGY P LTD	MUMBAI
PRONIC S.A	FRANCE
PROTEKZ	BANGALORE
PROTOSYS TECHNOLOGIES PRIVATE LTD	MUMBAI
PUNCH INDUSTRY (DALIAN) CO., LTD	DALIAN LIAONING, CHINA
QINGDAO HAIER MOULDS CO., LTD	QINGDAO, CHINA
RADIANT SAFEWAY P LTD	NEW DELHI
RASANDIK ENGINEERING INDUSTRIES INDIA LTD	NEW DELHI
RENATA PRECISION COMPONENTS P LTD	PUNE
RENISHAW METROLOGY SYSTEMS P LTD	BANGALORE
RGK ENGINEERING ENTERPRISES P LTD	BANGALORE
RIYA ELECTRODES P LTD	FARIDABAD (HARYANA)
RODS ALLOYS INTERNATIONAL	BANGALORE
RONTGEN SAWS P LTD	NAVI MUMBAI
ROSA UCAM GRINDTECH PVT LTD	BANGALORE
S T ENGINEERS	COIMBATORE
S K INDUSTRIES	BANGALORE
SANDHAR STEADY STREAM TOOLING P LTD	GURGAON
SANDSTORM EQUIPMENT CO.	BANGALORE
SANSHA SYSTEMS LTD	BANGALORE
SANTHOSH ENGINEERING EQUIPMENTS	BANGALORE
SECO TOOLS INDIA (P) LTD	PUNE
SERMO ARRK INDIA P LTD	PUNE
SESCOI INDIA SOLUTIONS P LTD	PUNE
SHEASHA TOOL SERVICES	BANGALORE
SHIBALLOY MULTIFLEX P LTD	BHUBANESHWAR
SHOWA TOOLS CO., LTD	JAPAN
SIMPOE SAS	FRANCE
SINGAPORE PRECISION ENGINEERING TOOLING ASSOCIATION	SINGAPORE
SLD ENTERPRISE INCORPORATION LTD	GUANGDONG, CHINA
SOB (SHINKANG OILLESS BEARING) CO., LTD	SOUTH KOREA
SODICK ENGINEERING SERVICE (THAILAND) CO. LTD.	BANGALORE
SORALUCE S. COOP	SPAIN
SPARKONIX (INDIA) PRIVATE LTD	PUNE
SRI GANESH SALES SERVICES	BANGALORE
SRIDEVI TOOL ENGINEERS P LTD	VASAI (E)
STIACK ENGINEERING P LTD	MUMBAI
STITCH OVERSEAS PRIVATE LTD	DELHI
STORES SUPPLY (INDIA) AGENCY PVT LTD	KOLKATA
SUHNER INDIA P LTD	BANGALORE
SYNVENTIVE MOLDING SOLUTIONS JBJ P LTD	BANGALORE
SYSTEM 3R FAR EAST PTE LTD	SINGAPORE
TAEGUTEC INDIA P LTD	BANGALORE
TAIPEI INDUSTRIES PTE LTD - TROOP	SINGAPORE

TAIZHOU-JINGCHAOLI MOULD PLASTIC CO., LTD	ZHEJIANG, CHINA
TAL MANUFACTURING SOLUTIONS LTD	PUNE
TAOSHI MOULD GROUP CO., LTD	ZHEJIANG, CHINA
TATA CONSULTANCY SERVICES	BANGALORE
TEBIS	GERMAN
TECH TOOLS	MUMBAI
TECHTRONICS INDIA LTD	GURGAON
TECNOSTAMPI DEI F.LLI PELIZZARI SRL	ITALY
TEKNOMEK	CHENNAI
THERMIC SERVICE SA	PORRENTROY
TITAN INDUSTRIES LTD	HOSUR
TRIMOS METROLOGY (I) PVT LTD	THANE
TRIMURTI CAD CAM PVT LTD	RAJKOT
UDAY COMPUTER AIDED MANUFACTURING (P) LTD	BANGALORE
UMS TECHNOLOGIES LTD	COIMBATORE
UNIMARK	MUMBAI
USBCO STEELS PRIVATE LTD	KOLKATA
VASANTHA TOOL CRAFTS P LTD	HYDERABAD
VIJAYDEEP MOULD ACCESSOIRES PVT LTD	MUMBAI
WALTER AG SINGAPORE PTD LTD	SINGAPORE
WALTER TOOLS INDIA P LTD	PUNE
WANCO INDUSTRIAL PTE LTD	SINGAPORE
WIKUS-NIRAN SAWS	MUMBAI
XEBEC TECHNOLOGY CO., LTD	JAPAN
XI'AN HIGH-TECH AEH INDUSTRIAL METROLOGY CO. LTD	XIAN, P.R. CHINA
XLAR ENTERPRISES	GHAZIABAD
ZHEJIANG HUANGYAN HAOMA PLASTIC MOULD CO., LTD	ZHEJIANG, CHINA
ZHEJIANG HUANGYAN MEIDUO MOULD FACTORY	ZHEJIANG
ZHEJIANG JIAREN MOULD CO., LTD	ZHEJIANG PROVINCE
ZHEJIANG KAIHUA MOULDS CO., LTD	ZHEJIANG, CHINA
ZHEJIANG SAIHAO INDUSTRIAL CO., LTD	ZHEJIANG, CHINA
ZHEJIANG TAIZHOU HUANGYAN JINGZHENG MOULD CO., LTD	ZHEJIANG, CHINA
ZHEJIANG XIAOSHAN GOLDEN TORTOISE MACHINERY CO. LTD	ZHEJIANG, PRC
ZOLLER ASIA PACIFIC LTD	HONGKONG
ZWCAD SOFTWARE CO., LTD	GUANGZHOU, CHINA
ZYFIX TOOLS (P) LTD	HYDERABAD

[TOP](#)