



AN INVITATION AND A WELCOME

[Page 1](#)

Sub.: The 5th DIEMOULD INDIA 2006 International Exhibition, Chennai..

From : 3rd March, 2006 to 6th March, 2006

Welcome for the 5th time to TAGMA's DMI-2006 international exhibition that transcends the borders of tooling technology in a world of rapid changes.

Welcome by an institution whose mission is fusion between international & national business.

Welcome to the hub and buzz of technical professionalism and unprecedented globalization.

Welcome to the home of customization, quick communication, intensive development and diverse opportunities covering a sub continent.

Welcome to India's inexhaustible resource materials, **global mindsets** and preferred technology acumen.

Welcome to the knowledge area of tool makers who would like to grow immeasurably and work together to achieve common goals.

Welcome to the country of "borderless thinking and limitless potential" for that success which is the summit and goal of all life.

Come and discover countless ways and exposure to newer perspectives of the world's **second largest populated country.**

Come and discover entrepreneurial enterprise and opportunities in the **second largest growth economy** of Asia with all its purchasing power.

Come where regional and local level have their appointed places to vie for a place in the sun via expansive opportunities.

Come where your industry and life work experiences can be shared with your peers in the full knowledge that DMI 2006 is just the right place for it.

And finally, come where you can establish business contacts around the world acquired from constant interaction with them with all their unique leverages.

Do you still need an invitation when you are already assured of a welcome?

Kind Regards,

**S.C.KALYANPUR
PRESIDENT**



FACT SHEET

**ON 5th DIEMOULD INDIA-2006
EXHIBITION AND
TOOLING IN THE NEXT DECADE VISION 2010 SEMINAR COVERING CURRENT
AND FUTURE DIE AND MOULD TECHNOLOGIES**

Time Table of site Operations	
Exhibitors	Move in Date
(a) Heavy Exhibits (Machine / Moulds)	1st March 2006
(b) Light Exhibits	2nd March 2006, 10 a.m.
Completed work on	3rd March 2006, 8 a.m.

Time Table	
Possession for Exhibitors:	
Raw Space	1st March 2006, 10 a.m.
Shell Space	2nd March 2006, 10 a.m.
Completion of displays	3rd March 2006, 8 a.m.
Inauguration of Exhibition	3rd March 2006, 10 a.m.
Duration of Exhibition	3rd March to 6th March 2006.
Dismantling of Exhibition	On 6th March 2006, 6 p.m. Onwards

Space Rental

	SHELL STAND	RAW SPACE
Member	Rs. 5400 p.m. ²	Rs. 4500 p.m. ²
Non-Member	Rs. 6000 p.m. ²	Rs. 5000 p.m. ²
Foreign	USD 200 p.m. ²	USD 175 p.m. ²
Minimum area	9 sq. M.	
Additional area	As required.	

Exhibitor Directory

Free entry as per standard questionnaire

Carnet
ITPO Approved NO. 144-ITPO (248) APP/2004

Exhibition timings
10 a.m. to 6 p.m.

Advertisements in Exhibitor Directory
Details are available on request. Open to all in the industry
Shell Stand Facilities

Standard Octonorm modular structure with partition, company name of fascia, carpet, one table, 2 chairs, 3 spotlights and one Power socket per 9 sq. m

Utilities

Overall security, watch & ward, and conservancy provided free. Charges for electricity and additional utilities, furniture etc. are as per contractual rate.

Payment

50% with booking and balance by 30th December 2005 by local cheque or demand draft.

Cancellation subject to 15% deduction of payment before 30th December 2005 after that 100%.

[TOP](#)



TERMS AND CONDITIONS

**GUIDELINES : DIEMOULD INDIA 2006 CHENNAI TRADE CENTRE, CHENNAI 600 089.
VISITOR TIMING: 10 A.M. TO 6 P.M.**

1. **POSSESSION OF RAW SPACE BUILD UP AND PLACEMENT OF MACHINERY AND OTHER EXHIBITS:** Raw space buildup & machinery : 1st March, 10.00 am. For Shell Stand without machinery : 2nd March, 10.00 am.
2. **INAUGURATION** : 10 a.m. on 3rd March 2006.
3. **DISMANTLING** : On 6th March 2006 from 6 p.m. onwards and to be Completed by 8 a.m. on 7th March 2006. Vacant possession of the stand area to be handed over by 10 a.m. on 7th March 2006.
4. **ACCOUNTS** : To be settled before closedown on 5th March 2006, 4 p.m.
5. **EXHIBITS** : See Fact Sheet
6. **DEMONSTRATION OF MACHINERY & EQUIPMENT** : All prescribed safety measures will be observed, particularly those relating to fire, heat and all other hazards to life, limb and property. Operating areas should be fenced off as a precautionary measure.
7. **REGULATIONS** : a) Exhibitor activity will be confined to the area allotted. There should be no abutting into common areas, passages or adjoining stands. B) Sub-letting of space is prohibited. C) Comprehensive insurance is in the interest of the exhibitor. D) TAGMA stands indemnified automatically.
8. **SITE HANDLING AND SERVICES TARIFF** : Available on request. Also will be sent as soon as booking is received.
9. **FREIGHT FORWARDING, CLEARING AND SOLE SITE HANDLING AGENCY : EXHIBITS HANDLING** : Buhariwala logistics, Balmer Lawrie building, 1st Floor, 5, J. N. Heredia Road, Ballard Estate, Mumbai – 400 001. Tel : +91 022 22625451 / 53, Fax : 91 – 22 – 22622724. Email : armayesh@buhariwalasglobal.com **Contact Person** : Mr. Armesh Buhariwala Or Mr. T. A. Sheikh -(M) 9892503453. Billing will be done direct by the handling agency for services rendered and must be settled with them direct.
10. **ACCOMODATION** : Hotels offering concessional tariffs will be sent to all participants.
11. **COMMON SERVICES** : Include general illumination and hall lighting, carpeting of aisles and passages, exhibitor passes, free entry in the directory and a copy of the directory to each exhibitor.
12. **ADDITIONAL FURNITURE AND FITTINGS:** To be ordered and hired direct from – Pavilions & Interiors. 017 Brahmasiddhi, Century Bazar Lane, Prabhadevi, Worli, Mumbai 400 025. Ph. : 2431 4891 / 2432 2190. FAX : 2460 4609. E- mail: Bompsi@bom5.vsnl.net.in Rentals to be paid direct.

13. **DIRECTORY** : Directory entries will be published as per details provided by the exhibitor in questionnaire.
14. **ADVERTISERS**: Advertisers will be given a voucher copy of the Directory with the Bill. Advertisement charges are to be paid in advance.
15. **General information** : . Chennai Trade Centre authorities from whom TAGMA has rented the exhibition premises have instructed us to follow their Manual which inter alia, states that – a) digging, painting of walls etc. will not be allowed and damages, if any, have to be compensated by the exhibitor. B) Adequate fire precautions should be taken (fire extinguishers are available from the contractors on hire).
 2. TAGMA decision on all matters is final and binding.
 3. All costs and consequences on any account are the liability of the exhibitors including Customs, Central Excise, Municipal Corporation and Chennai Trade Centre Exhibition Site.
16. **DUTY EXEMPTION : (1) INDIA TRADE PROMOTION ORGANISATION (ITPO)** has approved DIEMOULD INDIA 2006 and issued ATA Carnet facility under notification ITPO Approved No. 144-ITPO (248)/APP/2004 Customs at Mumbai, Calcutta, Chennai & New Delhi have been informed accordingly. (2) The Dy. Assessor & Collector, Chennai Municipal Corporation has also been intimated with a request for exemption of Octroi. (3) The Assistant Collector Central Excise has the authority under " General exemption No. 15" to extend bond facilities for movement of exhibits to and fro within specified time limits. (4) Octroi at place of origin : Exhibitors are advised to contact the Municipal authorities of their respective areas for completing the formalities there, to enable outward and inward movement of exhibits without incurring octroi payment at their respective Octroi posts. Separate manual will be sent to exhibitors in due course.
17. **GATE PASS** : TAGMA will issue gate pass for removal of exhibits as per original lists of exhibits brought in and certified at site.
18. **EXHIBITOR BADGES** : These will be available at the exhibition registration desk.
19. **INDEMNITY FORM** : This will also be made available at the registration desk which may be duly signed and returned by the exhibitor.

[TOP](#)



**PROPOSED LAYOUT FOR
 DIEMOULD INDIA -2006.**

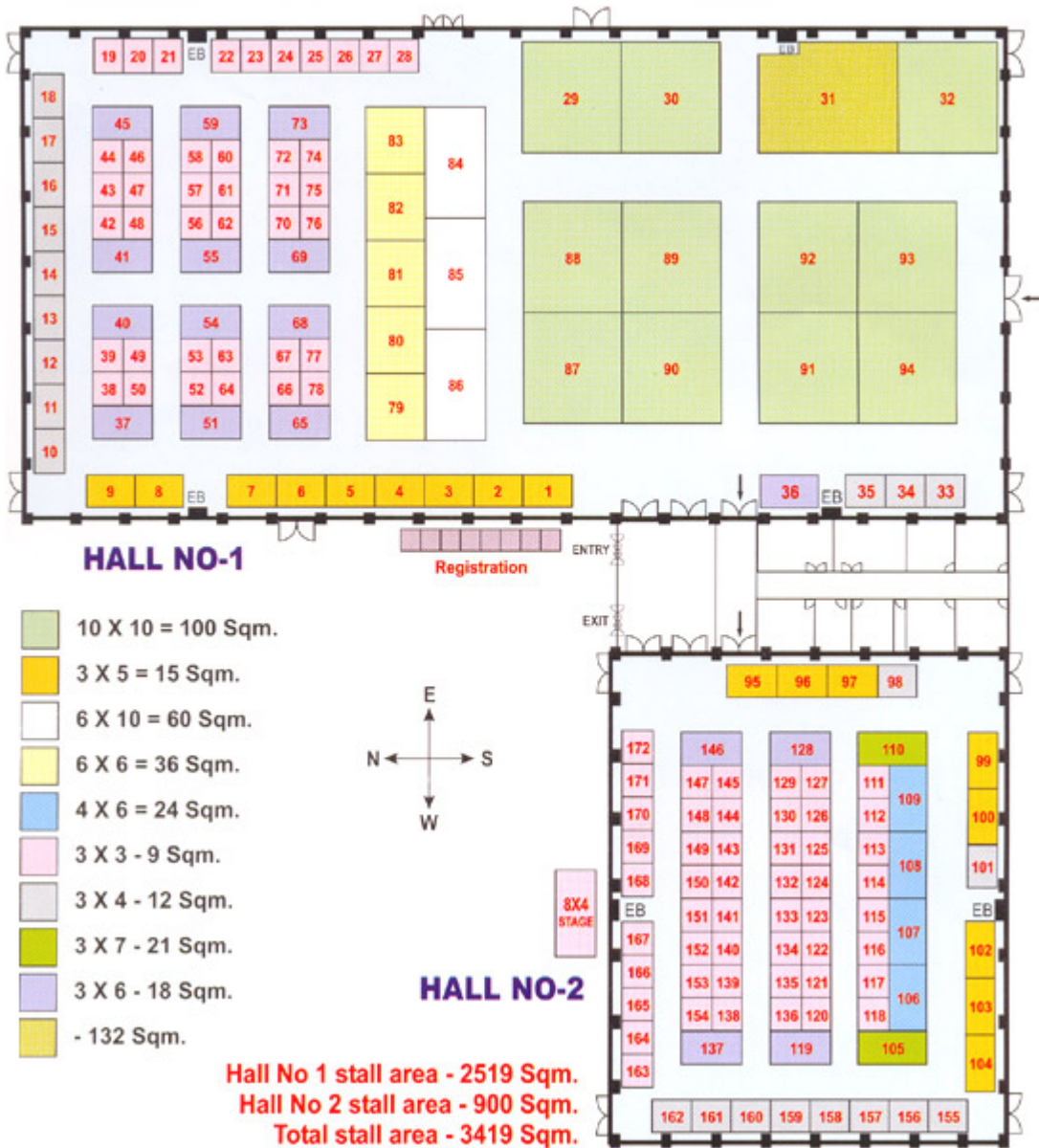



Please complete & return to :

TAGMA
TOOL AND GAUGE
MANUFACTURERS
ASSOCIATION

SPACE APPLICATION CONTRACT

Page 5

Organisation: _____

Contact Name : Mr. / Mrs. Ms. _____

Designation : _____

Address : _____

City : _____ Postal Code : _____ Country : _____

Tel : _____ Fax: _____

e-mail : _____

Exhibitor Details _____

Stand Packages

Shell Scheme Package this includes:

- Modular shell scheme back and side walls
- Fascia with company name and stand number
- Carpet
- 1 Power Point
- 3 spot lights per 9 sq.m.
- One Table
- 2 chairs
- Stand Cleaning

Raw space Package

- Bare Space only

Stand Allocation and Costs

Please Tick () ONE of the following options:

OPTION 1 SHELL SCHEME Shell stand: Minimum 9 sq. Metres Additional space Please specify sq. metres <input type="text"/>	AMOUNT	MEMBER Rs. 48600	NON MEMBER Rs. 54000	FOREIGN USD 1800
	TOTAL			
		MEMBER Rs. 40500	NON MEMBER Rs. 45000	FOREIGN USD 1575
OPTION 2 RAW SPACE Raw Space : Minimum 9 sq. metres Additional space Please specify sq. metres <input type="text"/>	AMOUNT			
	TOTAL			

RATES PER SQUARE METRE	ADDITIONAL SPACE	MEMBER Rs.	NON MEMBER Rs.	FOREIGN USD
	→			
	Shell Stand:	5400	6000	200
	Raw Space:	4500	5000	175
All payments to be made by drafts / cheque or TT to: TOOL AND GAUGE MANUFACTURERS ASSOCIATION INDIAN OVERSEAS BANK, CURRENT ACCOUNT NO. - 1881. NAND JYOT INDL. ESTATE BRANCH, ANDHERI-KURLA ROAD, MUMBAI - 400 072.				

Payment Terms

50% deposit with this application & 50% balance by December 30th, 2005.

PLEASE NOTE THAT CONFIRMATION OF YOUR BOOKING IS SUBJECT TO RECEIPT OF DEPOSIT PAYMENT

We hereby confirm our participation at DMI 2006 and also our acceptance of the terms and conditions printed overleaf which form a part of this contract.

Authorised Signature : _____ Name : _____

Designation : _____ Booking Date : _____

TOP



FREE DIRECTORY ENTRY

Please complete & return to :
TAGMA
TOOL AND GAUGE
MANUFACTURERS
ASSOCIATION

Page 6

Please complete in block capital letters correctly typed. **We will fill in the stand number.**

STAND NO.

Company Name _____

Address: _____

Phone No : _____ Fax No : _____

E-mail: _____

Exhibits: _____

Production Specialities : _____

Please indicate under which letter of the alphabet your company is to be listed. →

Signature

Name

Designation

TOP



ADVERTISEMENT IN DIRECTORY

Please complete in block capital letters correctly types. This form which is optional should be attached to Application for Display Space Form or can be sent separately before 30-12-2005.

Company Name : _____

Address : _____

Phone: _____ Fax : _____ Date : _____

e-mail : _____

Name of Signatory _____ Signature _____

Please reserve the following advertising space in the **DIEMOULD INDIA – 2006** Directory
Payment & Materials will follow on demand.

ADVERTISING RATES	INDIAN ADVERTISEMENTS	FOREIGN ADVERTISEMENTS
	Four Colour Rs.	Four Colour USD
Full A5 Page	8000	300
Front Inside	12000	500
Back Inside	12000	500
Back Cover	12000	NA
Section Separator / Divider	10000	500
Double Spread	15000	750

TECHNICAL DATA & DETAILS

a) Print area 12 cms. x 19.5 cms.	e) Booking on first come reserved basis
b) Bleed Size 14 cms. x 22 cms.	f) Color Printing on Sinar Mass Art Paper
c) Screen for color ads : 133 lpi.	g) If artwork is sent, actual processing charges will be extra.
d) 5% Cash discount for advance payments received with stand reservation application	h) DD/ Cheque payable to : TOOL AND GAUGE MANUFACTURERS ASSOCIATION



STANDARD EQUIPMENT FOR BUILT UP BOOTH

LAST DATE FOR PLACING THE ORDER : 15-02-2006.

Please fill this form in bold letters.

Hall No. : _____

Stand No. : _____

Exhibitor's Name : _____

Address : _____

Phone Nos. : _____

E-mail : _____

Fax : _____

Contact Person : _____

ADDITIONAL ITEMS ORDER FORM

SR NO.	DESCRIPTION	UNIT COST	QTY	TOTAL
1	REVOLVING CHAIR	800.00		
2	VISITOR CHAIR	300.00		
3	FOLDING CHAIR	150.00		
4	BAR STOOL	500.00		
5	GLASS COUNTER	1500.00		
6	ROUND TABLE	750.00		
7	SQUARE TABLE	750.00		
8	COUNTER (TABLE)	750.00		
9	SHOW CASE	2500.00		
10	WALL SHELVING (EACH)	300.00		
11	PHOTO CLIP / T-BOLT	10.00		
12	SPOT LIGHT (100 W)	200.00		
13	POWER SOCKET	200.00		
14	TUBE LIGHT	250.00		
15	FRIDGE	3,200.00		
16	HALOGEN (500 W)	350.00		

PLEASE NOTE:

1. ALL ITEMS ARE ON RENTAL ONLY FOR THE PERIOD OF EXHIBITION
2. PAYMENTS IN FULL MUST ACCOMPANY THIS ORDER BY DRAFT OR TT.
3. 30% EXTRA WILL BE CHARGED ON ALL ORDERS PLACED AFTER DUE DATE, SUBJECT TO AVAILABILITY.
4. ALL RATES IN THE TABLE ARE IN INDIAN RUPEES.
5. RATES ARE APPLICABLE FOR PARTICIPANTS OPTING FOR SHELL SCHEME ONLY.
6. PLEASE REFER TO THE ADDITIONAL ITEMS BROCHURE FOR PHOTOGRAPHS OF ALL THE GIVEN ITEMS.
7. ANY QUESTIONS REGARDING THE GIVEN ITEMS CAN BE ANSWERED BY CONTACTING OUT OFFICE.
8. WHEN YOU ORDER QUOTE SERIAL NUMBER AND QUANTITY REQUIRED.

PAVILIONS and INTERIORS

017, Brahmasiddhi, Century Bazar Lane, Prabhadevi, Worli, Mumbai – 400 025.
Tel : 022 – 2431 4891/2432 2190 FAX : 022 – 2436 2872.

SIGNATURE: _____

DATE : _____

TOP



Exhibit Range

Stand Packages

- Dies & Moulds, Press Tools.
- Machine Tools for making Dies & Moulds, C.N.C Milling / machining centre, E.D.M etc.
- Die casting machine / moulding machine.
- CAD / CAM system related to Dies & Moulds.
- Measuring Machines.
- Rapid Prototyping & Modeling.
- Digitising.
- Accessories for Machine Tools.
- Heat Treatment.
- Cutting Tools.
- Die / Mould polishing machines.
- Mould base and standard parts for Dies & Moulds.
- Die Spotting.
- Hot Runner Systems.
- Texturising.
- Gauges.
- Tool Steel.



Please complete & return to :
TAGMA
TOOL AND GAUGE
MANUFACTURERS
ASSOCIATION

TAGMA SPECIAL PUBLICATIONS

Page 10

Advertising Tariff & Technical Data In DIEMOULD INDIA 2006 Directory & Tagma Times

We have the following two publications in the offing:

1. DIEMOULD INDIA 2006 Exhibition Directory (DMI 2006)
2. DMI 2006 Preview Issue of TAGMA TIMES.

Tariff & Technical data are as follows

Name of Publication	DMI 2006 Exhibition Directory	TAGMA TIMES Preview issue
Bleed and overall size in cms.	14 x 22	21 x 28
Print area in cms.	12 x 19.5	18 x 25
Upto 4 colors Cover Page 2,3 & 4	Rs. 12,000.00	-
Upto 4 colors Divider Page rate	Rs. 10,000.00	-
Upto 4 colors Ordinary Page rate	Rs. 8,000.00	Rs. 6,000.00
Screen	Color - 133 B/W - 120	Color - 133 B/W - 120

ART PAPER WILL BE USED FOR ALL ADS.

ADS & ARTICLES CAN BE ISSUED AS A SUPPLEMENT TO TAGMA TIMES. RATE WILL BE SENT ON REQUEST.

TOOL AND GAUGE MANUFACTURERS ASSOCIATION.

For more details contact : TAGMA, Fax : 2850 3273.

e-mail : tagma@mtnl.net.in

NORMAL TAGMA TIMES MONTHLY PUBLICATION ADVERTISEMENT RATES APPLY ONLY TO THE CONTRACT ADVERTISERS FOR THE EXHIBITION PREVIEW ISSUE. THEY DO NOT COVER CASUAL ADVERTISERS AND NEW COMERS WHO HAVE PLACED THEIR ADVERTISEMENTS IN THE SPECIAL PREVIEW ISSUE OF TAGME TIMES IN FEBRUARY 2006.

[NOTE: Click here to download the entire set of DIEMOULD INTERNATIONAL EXHIBITION BROCHURE](#)

TOP



STANDARD SHELL SCHEME BOOTH (3M X 3M)

STANDARD SHELL SCHEME BOOTH (3M X 3M)

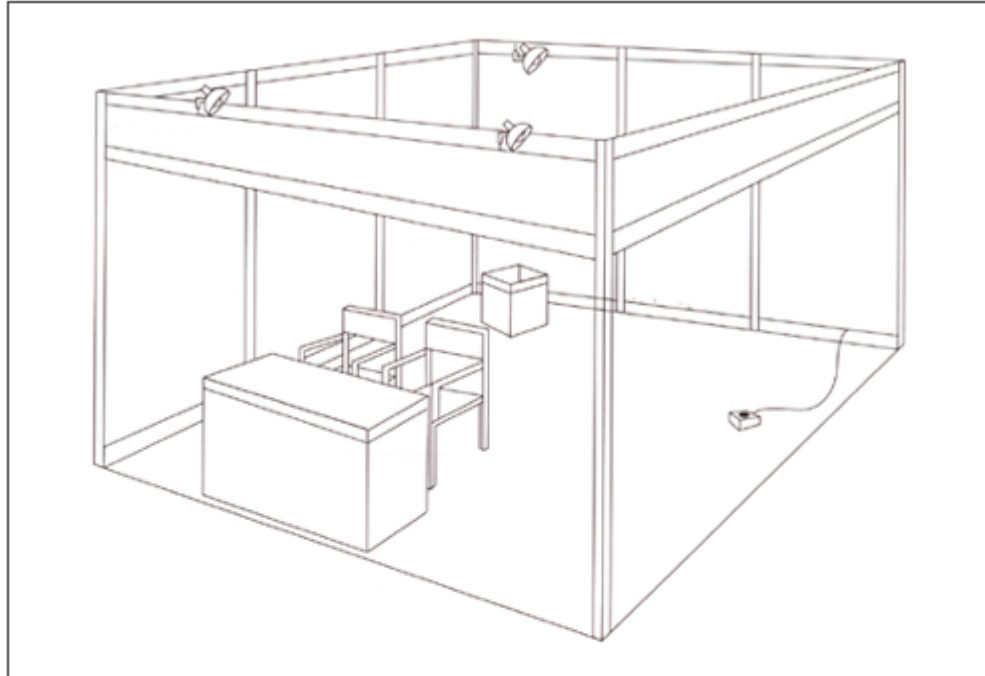

STANDARD EQUIPMENT SUPPLIED WITH BUILT - UP BOOTHS

Area	Chair	Table	Round Table	Spot Light	Socket	W.P.B.
9	2	1	-	3	1	1
12	2	1	-	6	1	1
18	3	2	-	6	1	1
24	6	2	-	12	2	2
36	8	3	1	15	2	2
42	10	3	1	18	4	3

NOTES:
 (1) No Nailing or painting is allowed on aluminium frames and panels

A TYPICAL 3M X 3M BOOTH

FRONT PERSPECTIVE VIEW

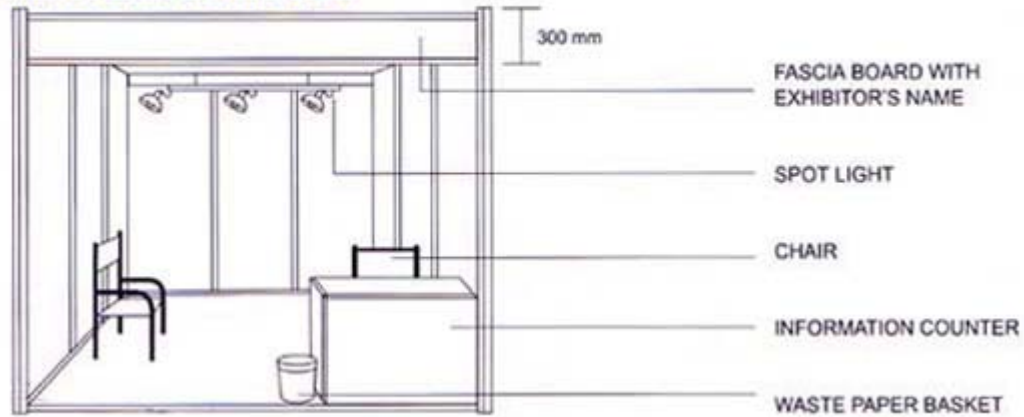

SIDE SECTIONAL ELEVATION

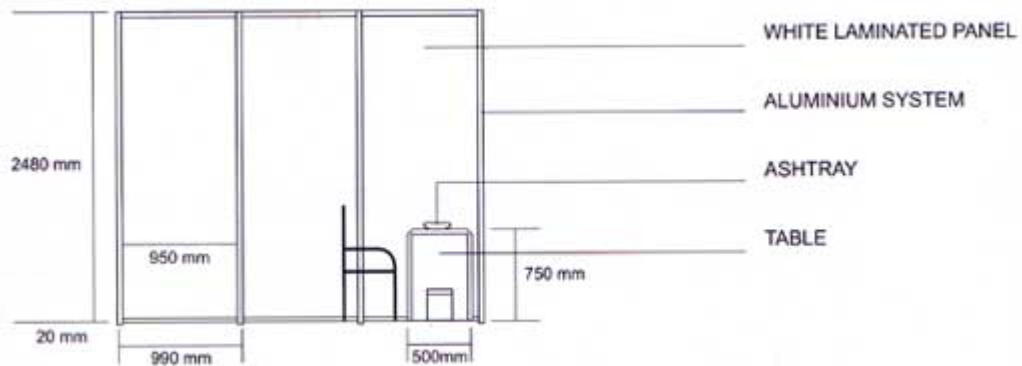

FLOOR PLAN

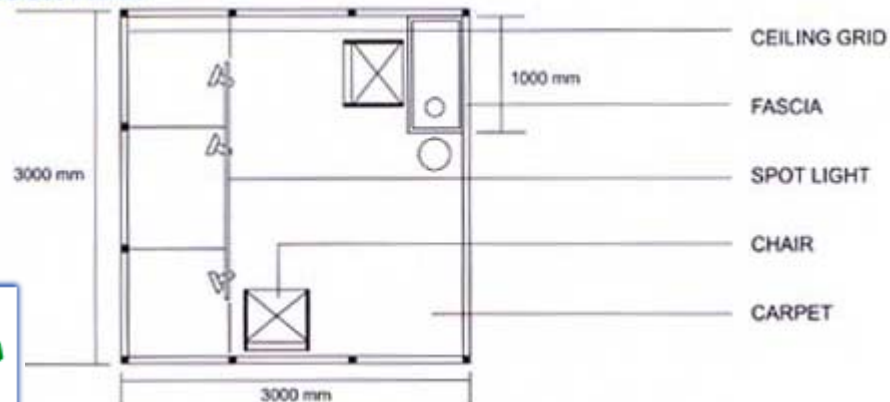

TRAVEL AGENT

Sita Mice

308, Town Center,
Nr. Mittal Indl. Estate, A.K.Road
Andheri (E), Mumbai 400 059

Tel: 022 - 56492000

Fax: 022 - 56492001, 56492002

Email: bom.mice@sitaindia.com

Website: www.sitamice.com

05th Die and Mould India International Exhibition-From 03rd to 06th Mar' 06 (Chennai Trade Centre)

Sr.no	Hotel	Category	Room Per Night		Rooms	Location	Comp Airport	Distance in Kms	Time from Venue
			INR	USD					
1	Radisson GRT-Chennai	05 Star				GST Road	No	04 Kms	10 Min
	Standard Single Room		6000 CPAI	120 CPAI	25				
	Standard double Room		6500 CPAI	130 CPAI					
2	Trident Hitton-Chennai	05 Star				GST Road	No	04 Kms	10 Min
	Standard Single Room		4500 CP + Tax	125 CP + Tax	25				
	Standard double Room		4500 CP + Tax	125 CP + Tax					
3	Le Meridien-Chennai	05 Star					Yes	06 kms	15 Min
	Superior Single Room		5100 CP + Tax	130 CP + Tax	25	GST Road			
	Superior double Room		5600 CP + Tax	150 CP + Tax					
4	Radha Park Inn	04 Star						15 Kms	40 Min
	Standard Single Room		2900 CP + Tax		10	Arumbakkam	No		
	Standard Double Room		3400 CP + Tax						
	(Indicative rates)								
5	Ambica Empire	03 Star			15	Arumbakkam	No	16 Kms	40 Min
	Standard		2450						

	Single Room		CPAI						
	Standard Double Room		3000 CPAI						
6	Vijay Park	03 Star						18 Kms	45 Min
	Standard Single Room		1800 CPAI		20	Arumbakkam	No		
	Standard Double Room		2100 CPAI						
7	Mount Heera	03 Star						08 Kms	20 Min
	Standard Single Room		1000 CP + Tax		5	GST Road	No		
	Standard Double Room		1200 CP + Tax			Near to Airport			
	Deluxe Single Room		1200 CP+ Tax		10		No		
	Deluxe Double Room		1400 CP+ Tax						
	(Indicative rates)								
8	Mount Manor	02 Star						08 Kms	20 Min
	Standard Single Room		800 EP + Tax		5	GST Road	No		
	Standard Double Room		900 EP + Tax			Near to Airport			
	Deluxe Single Room		1000 EP + Tax		10		No		
	Deluxe Double Room		1200 EP + Tax						
	(Indicative rates)								
9	Ashok Residency	02 Star						07 Kms	20 Min
	Standard Single Room		700 EP + Tax		5	Mount	No		
	Standard Double Room		850 EP + Tax			Poonamalla Road			
	Deluxe Single Room		995 EP + Tax		10		No		
	Deluxe Double Room		1150 EP + Tax						

(Indicative rates)									
--------------------	--	--	--	--	--	--	--	--	--

Please note -

- * CP - Inclusive Of breakfast.
- * CPAI - Inclusive Of breakfast and taxes.
- * EP - room only basis.
- * Luxury Tax will be charge on published Tariff (Presently tax applicable is 12.50%).
- * Government Service Tax (Presently 4.08%) is not included and will be charged on the total invoice amount.
- * Should there be any change in the tax rate/structure the revised rate will be charged.
- * The check in and Check- out time at hotels is normally 1200 Noon.
- * A one-night deposit is required to confirm each reservation.

[TOP](#)